

ATOMIZZATORI
SPRAYERS
SPRÜHGERÄTE
ATOMISEURS



MADE IN ITALY



Dragonne®

INDICE

INDEX



ATHOS pag 2



ATHOS ASP.ANT. pag 3



TAV pag 4-5



ATHOS T pag 6



γ pag 7



K1-K2 pag 8-9



GL 2+2 pag 10-11



VIRGOLA pag 13



GR pag 12

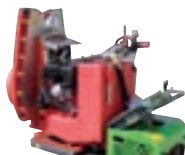

CAR pag 14



LG VIGNETO pag 15



AZ pag 15



LG pag 18



AZ2 pag 17



ATHOS

ATOMIZZATORE PER VIGNETO E FRUTTETO CONVENZIONALE A VENTILATORE ASSIALE

🇮🇹 Conventional sprayer for vineyards and orchards with axial fan

🇩🇪 Konventionell Sprühgerät für Weinberg und Obstbaum mit axial Gebläse



🇫🇷 Atomiseur adapte pour vignobles et fruitiers avec ventilateur axiale



VENTILATORE A PALE REGOLABILI
FAN WITH ADJUSTABLE BLADES
EINSTELLBARES FLÜGELGEBLÄSE
VENTILATEUR A PALETTES REGLABLES

TYPE		☀️ [mm]
PORTATO MOUNTED AUFSELTEL PORTÉ	200 lt	500-600-700
	300 lt	500-600-700
	400 lt	600-700-800
	500 lt	600-700-800
	600 lt	700-800
TRAINATO TRAILED NACHLÄUFER TRAINÉ	600 lt	700-800
	800 lt	700-800
	1000 lt	800-900
	1500 lt	900
	2000 lt	900
	3000 lt	900

ATOMIZZATORE PER VIGNETO, FRUTTETO E NOCCIOLETO CON VENTILATORE ASSIALE AD ASPIRAZIONE ANTERIORE

-  *Conventional sprayer for vineyards and orchards with axial fan*
-  *Konventionell Sprühgerät für Weinberg und Obstbaum mit axial Gebläse*
-  *Atomiseur adapte pour vignobles et fruitiers avec ventilateur axiale aspiration à l'avant*

ATHOS

ASPIRAZIONE ANTERIORE

3





TYPE		 [mm]
PORTATO MOUNTED AUFSATTEL PORTÉ	200 lt	600-700
	300 lt	600-700
	400 lt	700-800
	500 lt	700-800
	600 lt	700-800
TRAINATO TRAILED NACHLÄUFER TRAINÉ	600 lt	700-800
	800 lt	700-800
	1000 lt	800-900
	1500 lt	900
	2000 lt	900
	3000 lt	900

VENTILATORE A PALE REGOLABILI
 FAN WITH ADJUSTABLE BLADES
 EINSTELLBARES FLÜGELGEBLÄSE
 VENTILATEUR A PALETTES REGLABLES



ATOMIZZATORE PER VIGNETO E FRUTTETO DOTATO DI DOPPIO VENTILATORE CENTRIFUGO CONTROROTANTE PROGETTATO PER TRATTAMENTI A BASSO VOLUME

-  *Sprayer for vineyard and orchard, equipped with double against rotating fan, planned for low volume treatments*
-  *Sprühgerät für Weinberg und Obstbaum, mit doppel Gegenläufige Gebläse ausgestattet, für niedrige Volumen Behandlungen geplant*
-  *Atomiseur adapte pour vignobles et fruites avec double controrotatif centrifuge ventilateur pour les traitements à bas volume*



TYPE		 [mm]
PORTATO MOUNTED AUFSATTEL PORTÉ	200 lt	n° 2 x Ø 400
	300 lt	
	400 lt	
	500 lt	
TRAINATO TRAILED NACHLÄUFER TRAINÉ	γ 600	
	γ 1000	
	600 lt	
	800 lt	
	1000 lt	
	1500 lt	
2000 lt		

Profilo di distribuzione verticale
 Profile of vertical distribution
 Profil der vertikalen Verteilung
 Profile de la distribution verticale

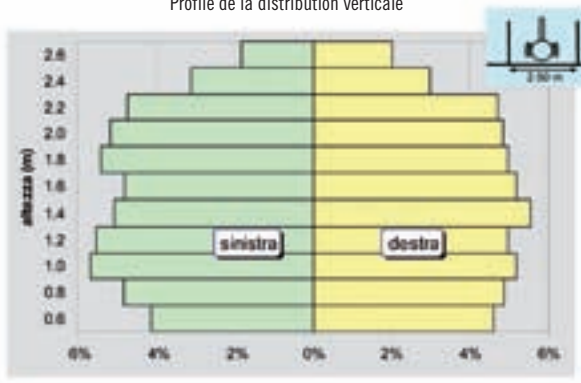

DATI BY ENAMA

**DOPPIO VENTILATORE
 CONTROROTANTE**
 DOUBLE AGAINST
 ROTATING FAN
 DOPPEL GEGENLÄUFIGE
 GEBLÄSE
 DOUBLE VENTILATEUR
 CONTROROTATIF

Velocità dell'aria rilevata a 0.50 m dall'uscita
 Air speed measured 0.50 m from outlet
 Luftgeschwindigkeit gemessen 0.50 m von Ausgang
 Vitesse du vent mesurée à 0.50 m de la sortie

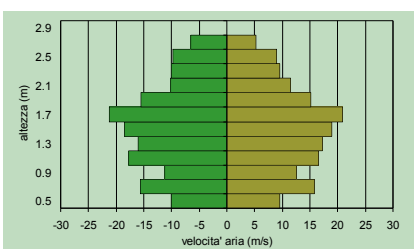

I - 1890 giri/min

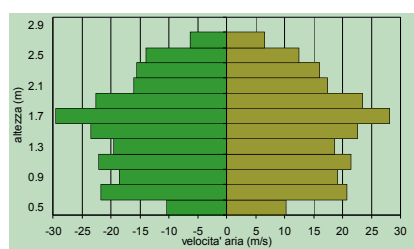

II - 2700 giri/min

**DISTRIBUZIONE
 SIMMETRICA DX/SX**
 SYMMETRICAL DISTRIBUTION
 RIGHT/LEFT
 SYMMETRISCHE VERTEILUNG
 RECHTS/LINKS
 DISTRIBUTION SIMMETRIQUE
 DROITE/GAUCHE



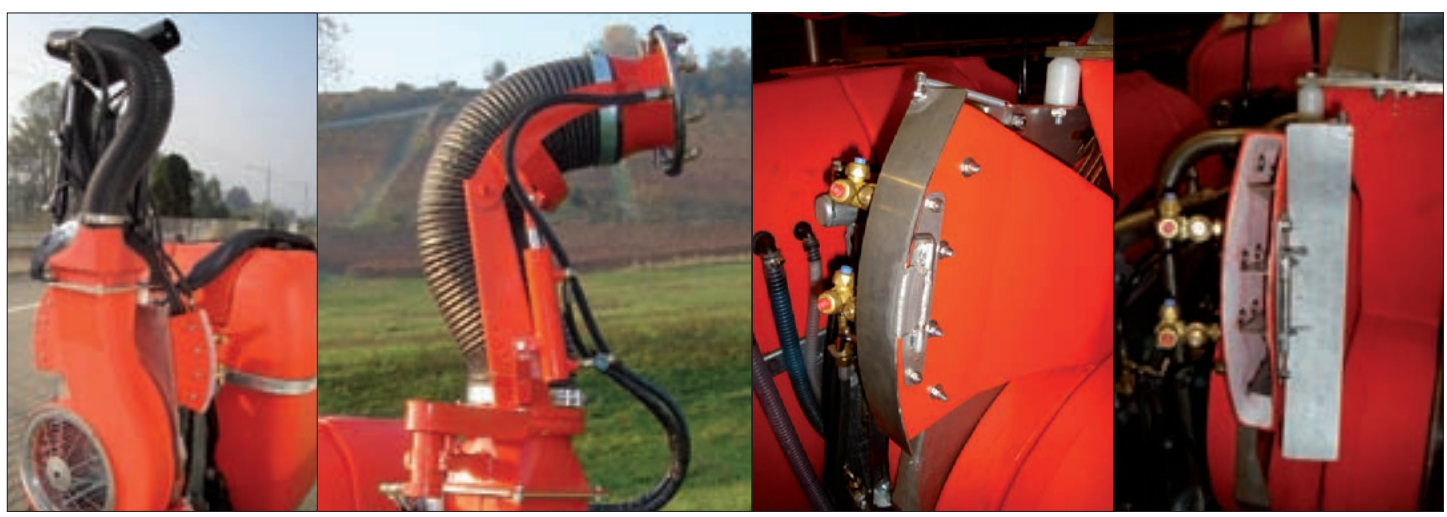

TIMONE STERZANTE GB1
 STEERING DRAWBAR GB1
 KNICKDEICHSEL GB1
 BRAQUANT GB1



ATHOS T

ATOMIZZATORE PER VIGNETO E FRUTTETO A VENTILATORE ASSIALE CON CONVOGLIATORE A TORRE

-  *Sprayer for vineyards and orchards with axial fan and tower-shaped conveyor*
-  *Sprühgerät für Weinberg und Obstbaum mit axial Gebläse und Turm-Förderer*
-  *Atomiseur adapte pour vignobles et fruitiers avec ventilateur axiale et convoyeur a tour*





VENTILATORE A PALE REGOLABILI
FAN WITH ADJUSTABLE BLADES
EINSTELLBARES FLÜGELGEBLÄSE
VENTILATEUR A PALETTES REGLABLES

TYPE		 [mm]
PORTATO MOUNTED AUFSÄTTEL PORTÉ	200 lt	600-700
	300 lt	600-700
	400 lt	700-800
	500 lt	700-800
TRAINATO TRAILED NACHLÄUFER TRAINÉ	400 lt	600
	500 lt	600-700
	600 lt	600-700
	800 lt	700-800
	1000 lt	800

ATOMIZZATORE PER VIGNETO E FRUTTETO MOLTO COMPATTO DOTATO DI DOPPIO VENTILATORE CONTROROTANTE AD ASPIRAZIONE ANTERIORE PER TRATTAMENTI A VOLUME MEDIO-BASSO PROGETTATO PER LE COLTIVAZIONI COLLINARI



-  *Sprayer for vineyard and orchard, very compact, equipped with double against rotating fan with front air inlet for medium-low volume treatments, planned for hills cultivations*
-  *Sprühgerät für Weinberg und Obstbaum, sehr kompakt, mit doppel gegenläufige Gebläse mit vorder Absaugen ausgestattet, für mittlere-niedrige Volumen Behandlungen, für der Hügelanbau geplant*
-  *Atomiseur pour vignobles et fruitiers avec double controrotatif ventilateur avec aspiration à l'antérieur pour le traitements sur les cultivassions en colline*



TYPE	☼ [mm]
γ 600	C 600
	E 600
	T 600
	C 700
	T 700
	C 800
	KRUMM Ø 450
γ 1000	C 600
	E 600
	T 600
	C 700
	T 700
	C 800
	KRUMM Ø 450

DOPPIO VENTILATORE CONTROROTANTE
DOUBLE VENTILATEUR CONTROROTATIF
DOUBLE AGAINST ROTATING FAN
DOPPEL GEGENLÄUFIGE GEBLÄSE



ATOMIZZATORE CON DOPPIO VENTILATORE CONTROROTANTE A DOPPIA ASPIRAZIONE PER VIGNETO E FRUTTETO DOTATO DI OTTIMA SIMMETRIA DI DISTRIBUZIONE SUI 2 LATI E FLUSSO UNIFORME SU TUTTA LA PARETE VERTICALE

- 🇬🇧 *Sprayer with double against rotating fan for vineyards and orchard with optimal distribution symmetry on both sides and uniform flow on the whole vertical wall*
- 🇩🇪 *Sprühgerät mit doppel gegenläufige Gebläse mit Doppelabsaugen für Weinberg und Obstbaum mit sehr gut Verteilung Symmetrie auf die beide Seiten und gleichförmige Strom auf die ganze vertikale Wand*
- 🇫🇷 *Atomiseur avec double ventilateur controrotatif avec double aspiration pour vignobles et fruitiers avec très bon symétrie de distribution sur les deux côtés et uniformité sur tut le paroi verticale*



MONOASPIRAZIONE



DOPPIO VENTILATORE CONTROROTANTE
DOUBLE VENTILATEUR CONTROROTATIF
DOUBLE AGAINST ROTATING FAN
DOPPEL GEGENLÄUFIGE GEBLÄSE

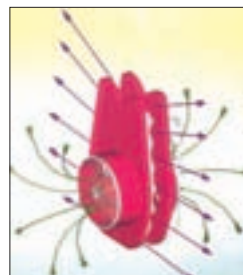

TYPE		☼ [mm]
PORTATO MOUNTED AUFSATTEL PORTÉ	200 lt	600
	300 lt	600
	400 lt	600-700
	500 lt	600-700



MONOASPIRAZIONE



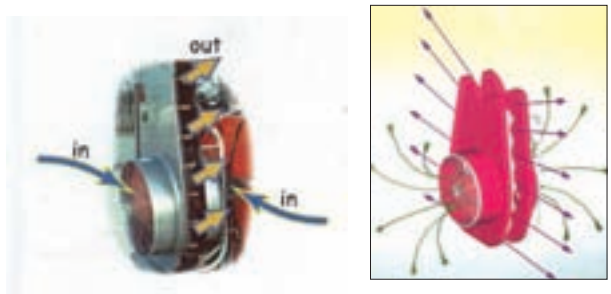

TYPE		☼ [mm]
TRAINATO TRAILED NACHLÄUFER TRAINÉ	400 lt	600
	500 lt	600
	600 lt	600-700
	800 lt	600-700
	1000 lt	700-800
	1500 lt	800
	2000 lt	800
	3000 lt	800

DOPPIO VENTILATORE CONTROROTANTE
 DOUBLE VENTILATEUR CONTROROTATIF
 DOUBLE AGAINST ROTATING FAN
 DOPPEL GEGENLÄUFIGE GEBLÄSE



ATOMIZZATORE SCAVALLANTE PER VIGNETO E PIANTE DA FRUTTO IN FILARE

-  *Straddle sprayer
for vineyard and fruit trees in row*
-  *Überzeilenspritze
für Weinberg und Obstbäume in Reihe*
-  *Atomiseur enjambeur
pour vignobles et fruitières en en rangées*





TYPE GL 2+2

PORTATO
MOUNTED
AUFSATTEL
PORTÉ

300 lt

400 lt

500 lt

TRAINATO
TRAILED
NACHLÄUFER
TRAINÉ

600 lt

800 lt

1000 lt

1500 lt



GRUPPI IRRORANTI DOTATI DI SERBATOIO E POMPA PER TUTTE LE APPLICAZIONI DI IRRORAZIONE E DISINFESTAZIONE IN CUI NON È NECESSARIO L'APPORTO DELL'ARIA

🇬🇧 *GR sprayer are recommended for spraying and disinfections without air need*

🇩🇪 *Zum Spritzen und Bewässern ohne Luftnotwendigkeit*

🇫🇷 *Pour l'irrotation ou l'apport de l'air n'est pas nécessaire*



DATI TECNICI SERBATOIO GR PORTATO
TECHNICAL DATA GR TANK SPRAYER WITHOUT FAN
TECHNISCHE ANGABEN GR BEHÄLTER OHNE GEBLÄSE
DONNÉES TECHNIQUES RÉSERVOIR ATOMISEUR GR SANS HÉLICE



Modello Type Typ Type	Serbatoio principale Main tank Hauptbehälter Réservoir principal	Serbatoio lavacircuito Circuit cleaning tank Spülbehälter Capacité de la cuve lave équipement	Serbatoio igiene operatore Handwash tank capacity Handwaschbehälter Capacité de la cuve lave mains
200	220 lt	30 lt	15v
300	330 lt	30 lt	15 lt
400	440 lt	50 lt	15 lt
500	550 lt	50 lt	15 lt
600	660 lt	64 lt	15 lt
800	880 lt	110 lt	15 lt
1000	1100 lt	110 lt	15 lt



TYPE GR	
PORTATO MOUNTED AUFSATTEL PORTÉ	200 lt
	300 lt
	400 lt
	500 lt
	600 lt
	800 lt
TRAINATO TRAYED NACHLÄUFER TRAINÉ	1000 lt
	400 lt
	500 lt
	600 lt
	800 lt
	1000 lt
	1500 lt
	2000 lt
3000 lt	



ATOMIZZATORE PORTATO COMPATTO PER LA VITICOLTURA COLLINARE E DI MONTAGNA

-  *Mounted sprayer designed for hill and mountain vineyard*
-  *Kompaktes Aufsattelsprühgerät für der Hügelig-und Gebirgsweinbau*
-  *Atomiseur porté compact pour la vigne en colline et en montagne*

VIRGOLA

TYPE		☼ [mm]
PORTATO MOUNTED AUFSATTEL PORTÉ	100 lt	500-600
	200 lt	500-600
	100 lt	T500-T600 *
	200 lt	T500-T600 *

* ATHOS T



INGOMBRI - SPACES - MABE - MESURES

TYPE	A (mm)	B (mm)	H (mm)
100 lt	820	950	1270
200 lt	890	1020	1090

ATOMIZZATORE PER PIANALE DI MOTOCARRIOLE O PER QUOAD, AZIONATO CON MOTORE A SCOPPIO O CON MOTORI IDRAULICI

 *Sprayer for floor of barrows or for Quoad, powered with combustion engine or with hydraulic engines*

 *Sprühgerät für Flachboden von Raupenfahrzeug oder für Quoad, mit Verbrennungsmotor oder hydraulische Antrieb betrieben*

 *Atomiseur pour poussoir à moteur ou Quoad, actionné avec moteurs hydrauliques*





TYPE	* [mm]	POWER
100 lt	ATHOS 500	HONDA GX390 13 hp
	ATHOS T 500	
100 lt	ATHOS 500	HYDRO
	ATHOS T 500	
200 lt	ATHOS 500	HYDRO
	ATHOS T 500	



ATOMIZZATORE A LUNGA GITATA CON VENTILATORE CENTRIFUGO ORIENTABILE CON COMANDI IDRAULICI A TRATTORE ADATTI PER VIGNETI E VIVAI

LG VIGNETO

15

-  *Sprayers with long range and centrifugal fan, adjustable with hydraulic controls on tractor, suitable for vineyards and nurseries*
-  *Sprühgerät mit lang Reichweite und zentrifugal Gebläse, durch hydraulische Armatur im Traktor einstellbar, geeignet für Weinberg und Baumschule*
-  *Atomiseur avec long jet et ventilateur centrifuge orientable avec commandes hydrauliques à tracteur adapte pour vignables et pépinières*

TYPE LG VIGNETO	* [mm]
200 lt	400
300 lt	
400 lt	

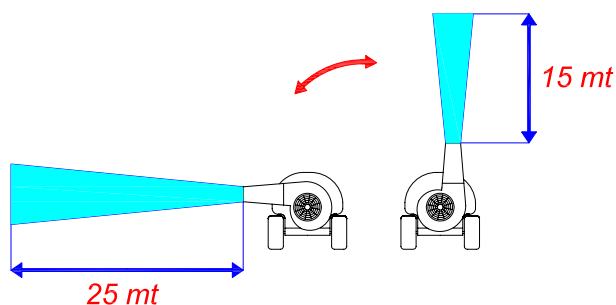

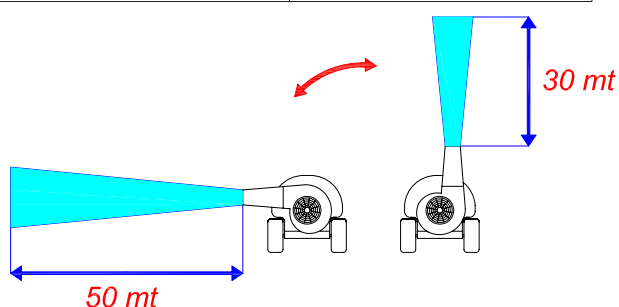

AZ

TYPE AZ	* [mm]
500 lt	450
500 lt	
600 lt	
800 lt	
1000 lt	





ATOMIZZATORE A LUNGA GITATA CON VENTILATORE CENTRIFUGO ORIENTABILE CON COMANDI IDRAULICI A TRATTORE ADATTI PER VIVAI, PIOPPETI, TRATTAMENTI SU CASTAGNO E ALBERI AD ALTO FUSTO

 *Sprayers with long range and centrifugal fan, adjustable with hydraulic controls on tractor, suitable for nurseries, poplar trees and treatments on chestnut and other high trunk trees*

 *Sprühgerät mit lang Reichweite und zentrifugal Gebläse, durch hydraulische Armatur im Traktor einstellbar, geeignet für Baumschule, Pappelpflanzung und Behandlungen auf Kastanienbaum und andere Hochstämmige Baume*

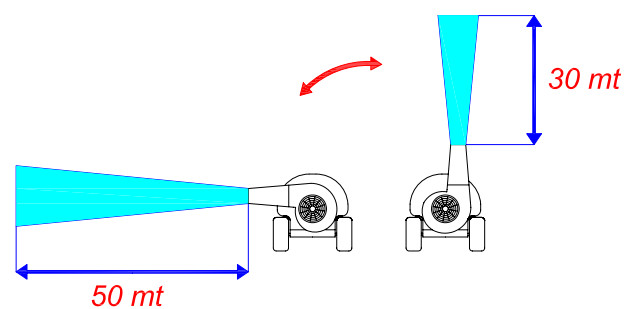
 *Atomiseur avec long jet et ventilateur centrifuge orientable avec commandes hydrauliques à tracteur adapte pour pépinières, peupleraie et traitemen sur châtaignier et autres arbres de haute futaie*



TYPE LG		 [mm]
PORTATO MOUNTED AUFSAITTEL PORTÉ	400 lt	450
	500 lt	
	600 lt	
	800 lt	
	1000 lt	
TRAINATO TRAILED NACHLÄUFER TRAINÉ	600 lt	
	800 lt	
	1000 lt	
	1500 lt	
	2000 lt	
	3000 lt	

ATOMIZZATORE A LUNGA GITATA CON DOPPIO VENTILATORE CENTRIFUGO ORIENTABILE CON COMANDI IDRAULICI A TRATTORE ADATTI PER VIVAI, PIOPPETI E TRATTAMENTI SU MAIS E GRANO

AZ2

17

- 🇨🇭 *Sprayers with long range and double centrifugal fan, adjustable with hydraulic controls on tractor, suitable for nurseries poplar trees and treatments on maize and corn*
- 🇩🇪 *Sprühgerät mit lang Reichweite und doppel zentrifugal Gebläse, durch hydraulische Armatur im Traktor einstellbar, geeignet für Baumschule, Pappelpflanzung und Behandlungen auf Mais und Korn*
- 🇫🇷 *Atomiseur avec long jet et double ventilateur centrifuge orientable avec commandes hydrauliques à tracteur adapte pour pépinières, peupleraie et traitemen sur mais et blé*

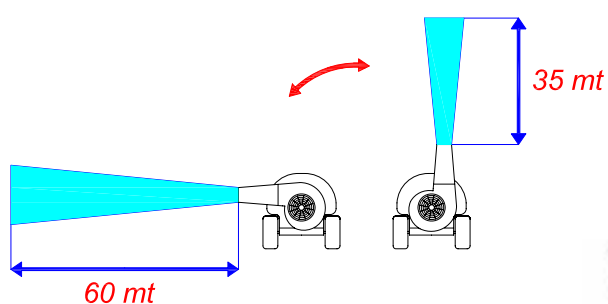



TYPE AZ 2		✱ [mm]
PORTATO MOUNTED AUFSAITTEL PORTÉ	400 lt	n° 2 x Ø 450
	500 lt	
	600 lt	
	800 lt	
	1200 lt	
RAINATO TRAILED NACHLÄUFER TRAINÉ	1000 lt	
	1500 lt	
	2000 lt	
	3000 lt	



 La ditta Dragone s.r.l. è presente da 50 anni nel campo della meccanica agricola e lavora costantemente per migliorare di anno in anno i propri prodotti. Gli ottimi risultati sono garantiti dalla meticolosità dei dipendenti della ditta e dalla preziosa collaborazione di esperti esterni che forniscono idee e consigli ragguardevoli. L'intero team aziendale lavora per raggiungere requisiti di qualità che vanno dalla progettazione alla produzione fino alla commercializzazione e all'assistenza dopo la vendita.

 The society DRAGONE works hard to improve every year its products in the sphere of the agricultural mechanisation. The Employers' work and the precious collaboration of external experts with their opinions and advices assure best results. Now we are working to achieve higher quality about projects and production till the trade and assistance after sales.

 Die Firma DRAGONE arbeitet daran um ihre Produkte im Bereich der Landwirtschaftlichbaumaschinen zu verbessern. Die Arbeit der Angestellten, der Firma und die Mitarbeit von Experten sind eine gute Gelegenheit um das Optimum zu erreichen. Wir werden alles daran setzen, wieder das Qualitätsniveau zu erreichen, das von jeher unser Stolz war. Die zukünftigen Lieferungen werden diese Tatsache bestätigen.

 La société DRAGONE travaille constamment pour améliorer d'année en année les produits pour ce qui concerne la mécanique agricole. Les résultats sont garantis par la méticulosité des dépendants de la maison et par la précieuse collaboration des experts extérieures qui fournissent des idées et des conseils remarquables. Nous travaillons pour rejoindre un haut niveau de qualité pour ce qui concerne le projet et la production jusqu'à la commercialisation et l'assistance après la vente.

 **Dragone**[®]

Dragone s.r.l.
Via G. Abbate, 189
14054 Castagnole delle Lanze (AT) Italy
tel. +39 0141 878582 - fax +39 0141 877108



www.dragoneweb.org
info@dragoneweb.org

